



SIDE FLEX

Elevate, integrate, and redefine product alignment

Elevate production efficiency

Engineered for impeccable product alignment and precise shifting, the Side Flex introduces a new standard of precision in your manufacturing process. Immerse your production line in a realm of unparalleled precision.

The Side Flex is easily integrated into your existing product line, and the flexible design isn't just a feature; it's a promise of adaptability to your specific operational needs.

Customize your needs

Choose between the standard version with length measurement or elevate precision with the scanner option for meticulous product alignment. Further, guarantee uncompromised quality with the reject feature, ensuring products beyond specifications are eliminated.

Main features

- Up to 160 products per minute
- Correction within +/- 60 mm
- Right or lefthanded solutions

- Flexible and adjustable conveyor: up to 20 degree tilt
- Few moving parts
- Low maintenance costs
- Hygienic design
- Standard version with length measurement

Option

- Scanner: precise product alignment
- Reject: reject products outside the specifications

Technical specifications SIDE FLEX

Capacity	Up to 160 products per minute (product depending)
Power supply	1 x 230VAC + N + PE
Power consumption	3 A
Max fuse	13 A
Frequency	50 Hz
Max short circuit current (IK Max)	6kA

Highlights

Compact design

Recipe controlled by Intry denester

Conveyor driven by drum motor with frequency converter

Scanner and reject option

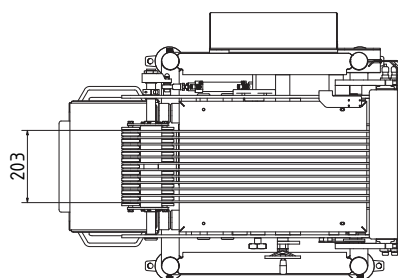
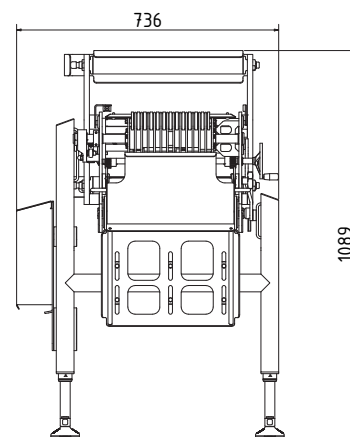
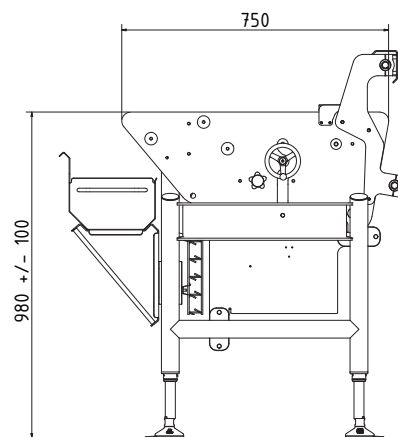

Specifications and photos are intended as a guide and can be changed by QUPAQ without notice. We make reservations for misprints and typing errors.